

6/1/2009



CHLORKING®
INC.

ON-SITE CHLORINE GENERATOR



X-GEN Chlorine Generator Specifications | Chlorking® Inc.

CHLORKING® X-GEN CHLORINE GENERATOR SPECIFICATIONS

1. The chemical sanitizer for the pool or spa shall be sodium hypochlorite, generated on site in an off line installation.
2. The ChlorKing® X-GEN system shall be NSF International standard 50 listed, and certified for use in pools and spas.
3. The electrical wiring, breakers, and disconnect boxes provided at the facility shall be UL listed components.
4. The X-GEN chlorine generator will produce 1,666 - 2,500ppm of sodium hypochlorite in a production tank from a concentration of 5,000ppm sodium chloride fed from a saturated salt feeder, or from a sea water feed system. No salt will be added to the pool directly.
5. The X-GEN chlorine generator must re-circulate the swimming pool water through the production tank to re-use any salt in the swimming pool.
6. The X-GEN chlorine generator shall not require a water softener.
7. The X-GEN system will produce from 13lbs to 40lbs per day (model specific) of equivalent chlorine as a solution of sodium hypochlorite.

MODELS AVAILABLE:

X-GEN 20 (up to 20lbs / day)
X-GEN 40 (up to 40lbs / day)

8. The X-GEN system is capable of functioning in temperatures between 15C and 40C.
9. The X-GEN system functions at salt concentrations of 5000ppm in the production tank. (No salt is added to the pool)
10. Chlorine delivery is controlled by an electrical diaphragm metering pump or venture distribution system, (Application specific).
11. Flow through the ChlorKing® X-GEN cell is adjustable to meet production requirements. Flow switches are included as safety devices.
12. The X-GEN power supply is comprised of two components, a POWER SUPPLY which measures 16.5"x 21.5" and a TRANSFORMER which measures 10" x 17". These components will be wall mounted and connected using the supplied power cables.
13. The X-GEN PRODUCTION TANK and HEAT EXCHANGER are supplied individually and require field assembly. These components shall be floor mounted.
14. The X-GEN PUMP shall be mounted to the floor and requires field connection.
15. The system shall be pre-wired, ready for field connection of power tied to the pool pump and control circuits. The plumbing of the production tank and accessories shall be done at the time of the installation.
16. The ChlorKing® X-GEN system shall be capable of satisfactory performance if installed as per the manufacturer's recommendations (reference the ChlorKing® X-GEN installation manual). An authorized

representative shall be located within a reasonable distance of the facility and shall be available to install and service the system as required.

17. The X-GEN power supply system shall be bonded via the bonding lug to the local common bonding grid. (ALL EQUIPMENT MUST BE BONDED) The bonding connector shall be conductively connected to the grounding means.
18. The ChlorKing® X-GEN system shall have salt concentration displayed in PPM, measured using a toroidal probe. (No moving parts and no calibration needed)
19. The ChlorKing® X-GEN power supply shall be water cooled and have no fans.
20.
 - a) The manufacturer warrants the electrical components, pumps and cell containment tank of the ChlorKing® X-GEN system to be free of defects for one year from date of installation.
 - b) The manufacturer warrants electrode plates of the ChlorKing® X-GEN system for one year, and then prorated for one year after. (See actual warranty statement for details)
 - c) The manufacturer warrants assembly and workmanship of components of the ChlorKing® X-GEN system to be free of defects for three years.
21. Technical support and equipment information is available at 800-536-8180

ELECTRICAL SPECIFICATIONS

MODEL:	MAX PRIMARY AC AMPS	SYSTEM INPUT VOLTAGE	BREAKER REQUIRED
X-GEN 20	24	240	30
X-GEN 40	32	240	60

X-GEN 40 Pound Tank System

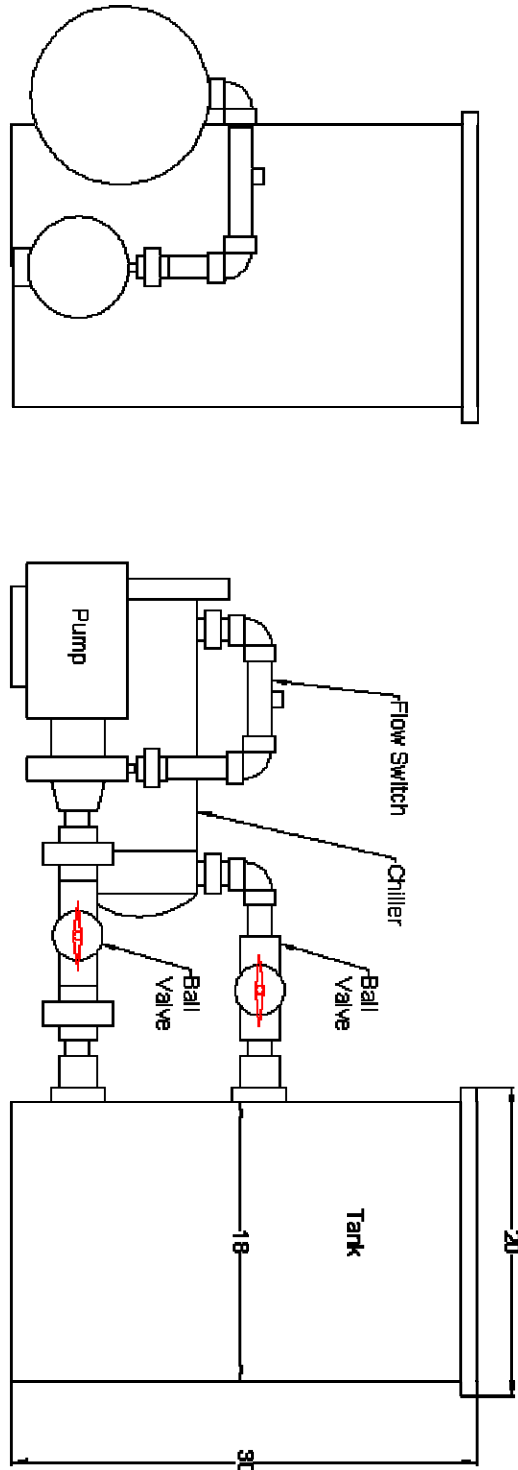

X-GEN 20 Pound Tank System

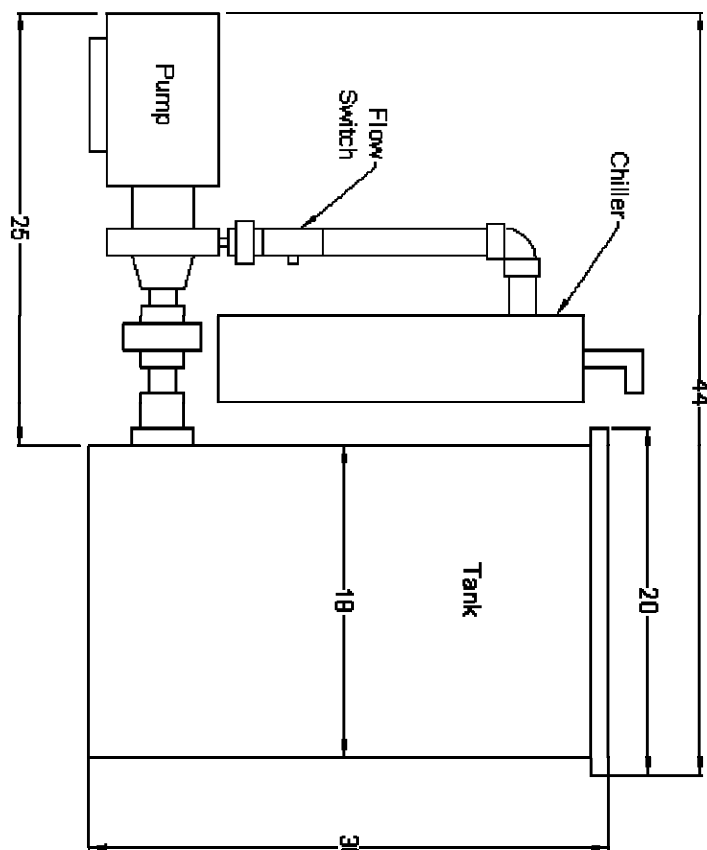
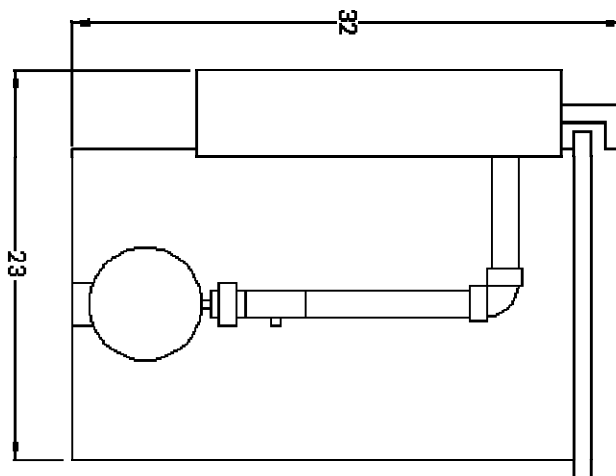



X-GEN Power Supply/Controller Box

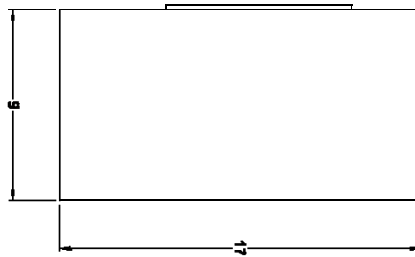
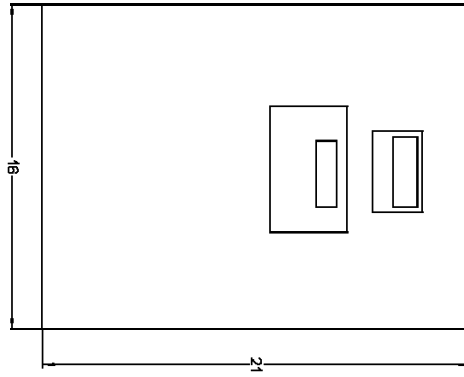

X-GEN 40 Pound Transformer

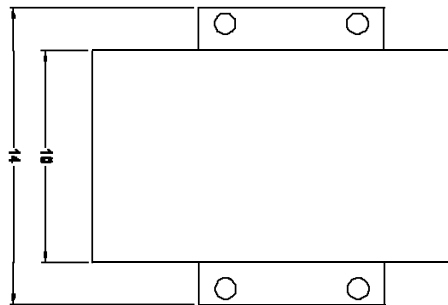

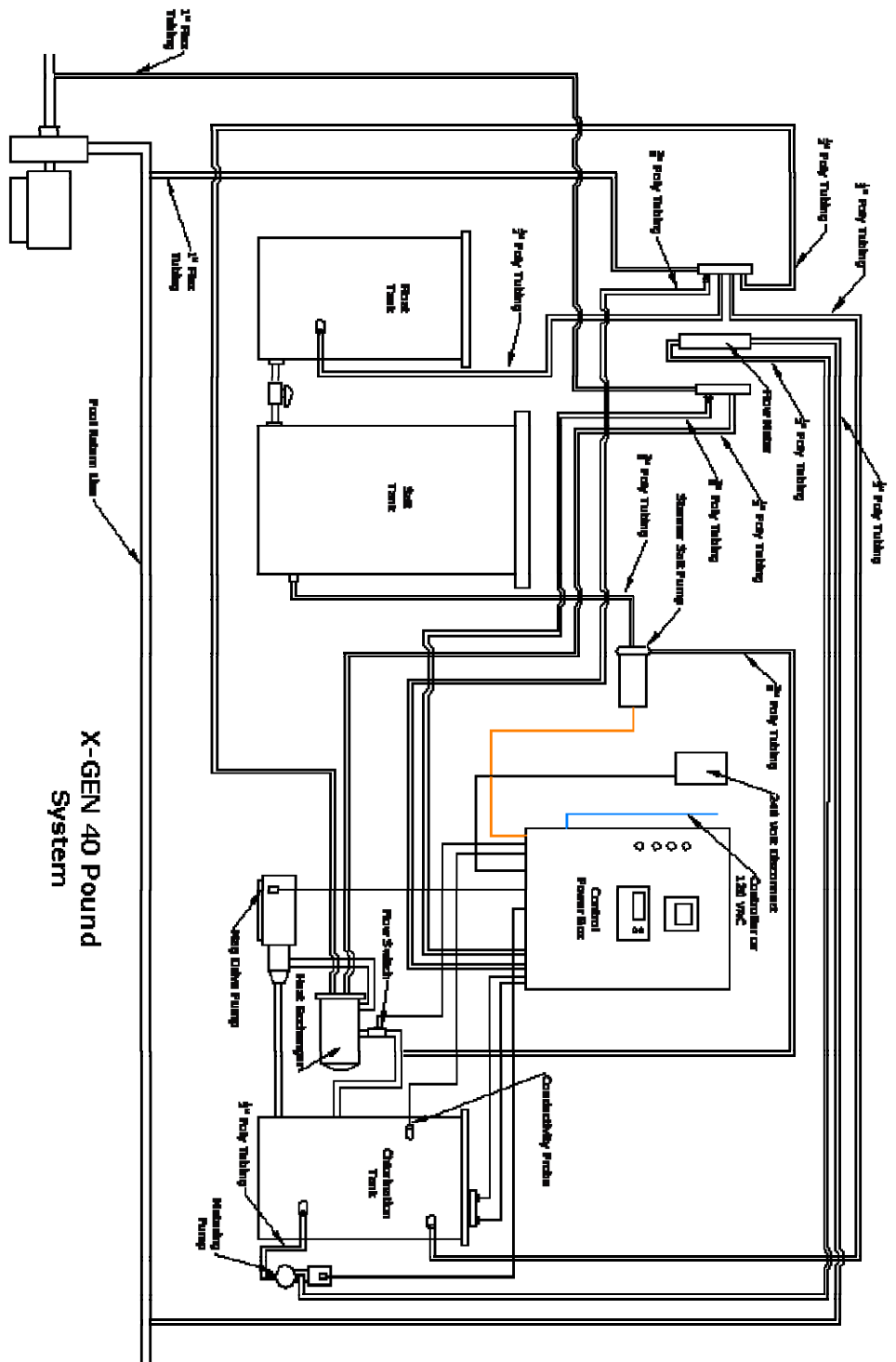

ChlorKing® Inc.

6767 Peachtree Ind. Blvd
Norcross, GA, 30092

Tel: 800-536-8180

Fax: 770-685-6576

www.chlorking.com

CHLORKING®
INC.

ON-SITE CHLORINE GENERATOR

